

General Specifications

SR10 Recorder

GS 4D8B2-E

The SR10 is a high cost performance digital recorder with a recording width of 100 mm. The model range includes 1-, 2- and 3-pen recorders and a 6 dot printing recorder, from which users can select either a DC voltage (DCV) & thermocouple (TC) model, or resistance temperature detector (RTD) model (for the 6 dot printing recorder only), depending on the type of input applied.

High reliability is realized by using in-house developed contact-free technology, such as high-breakdown solid-state relays. And also In servo-system a photoencoder is used to realize complete non-contact position detection.

The SR10 recorders are only 175 mm deep and can be used as a monitoring device and quality control instrument in many applications (such as process temperature monitoring, pollution, construction, furnaces, diagnosis, and refrigeration).



F0101.EPS

STANDARD SPECIFICATIONS

General Specifications

Construction

Mounting: Flush Panel Mounting (vertical), mounting next to each other (horizontal vertical). Mounting may be inclined up to 30° backward from vertical. Must not be tilted to the left or right.

Allowable panel thickness:
2 to 26 mm

Material: Case: modified poly phenylene ether, front door: polycarbonate

Finish: Case and door-frame:
lamp black (Mansell 0.8Y2.5/0.4 or equivalent)

Door: Splash and dust-proof (based on DIN 40050-IP54).

Dimensions:
144x144x175 mm (see dimensional drawings)

Weight (approx.):

1 pen	1.4 kg
2 pen	1.5 kg
3 pen	1.5 kg
6 dot	1.7 kg

Model

1-, 2-, 3- pen model and 6 dot model

Input

Inputs: DCV/TC Model

DCV: Direct current voltage input can range from ± 20 mV to ± 20 V.

TC: Thermocouple.

DCA: Direct Current Input (using external shunt resistor (10 Ω , 100 Ω , 250 Ω))

RTD Model (Only for Dot model)

RTD: Resistance Temperature Detector.

Measuring range:selectable per channel

DCV/TC Model

Input Type	Range	Measuring Range
DC V	20 mV	-20.00 to 20.00 mV
	60 mV	-60.00 to 60.00 mV
	200 mV	-200.0 to 200.0 mV
	2 V	-2.000 to 2.000 V
	6 V	-6.000 to 6.000 V
	20 V	-20.00 to 20.00 V

T01.EPS

Input Type	Range	Measuring Range °C	Measuring Range °F
TC	R*1	0.0 to 1760.0°C	32 to 3200°F
	S*1	0.0 to 1760.0°C	32 to 3200°F
	B*1	0.0 to 1820.0°C	32 to 3308°F
	K*1	-200.0 to 1370.0°C	-328 to 2498°F
	E*1	-200.0 to 800.0°C	-328.0 to 1472.0°F
	J*1	-200.0 to 1100.0°C	-328.0 to 2012.0°F
	T*1	-200.0 to 400.0°C	-328.0 to 752.0°F
	N*1	0.0 to 1300.0°C	32 to 2372°F
	W*2	0.0 to 2315.0°C	32 to 4199°F
	L*3	-200.0 to 900.0°C	-328.0 to 1652.0°F
U*3	-200.0 to 400.0°C	-328.0 to 752.0°F	

T02.EPS

RTD Model (Only for dot model)

Input Type	Range	Measuring Range °C	Measuring Range °F
RTD	Pt100*4	-200.0 to 600.0°C	-328.0 to 1112.0°F
	JPt100*4	-200.0 to 550.0°C	-328.0 to 1022.0°F

*1 R, S, B, K, E, J, T, N: IEC 584-1 (1995), DIN IEC584, JIS C 1602-1995

*2 W: W-5%Re/W-26%Re (Hoskins Mfg. Co.), ASTM E988

*3 L: Fe-CuNi, DIN 43710, U: Cu-CuNi, DIN 43710

*4 Pt100: JIS C 1604-1997 IEC 751-1995, DIN IEC 751-1996,

JPt100: JIS C 1604-1989, JIS C 1606-1989

T03.EPS

Measurement Interval:

Pen model: 250 ms/channel.
Dot model: 10 sec/6 channel

A/D Integration Time:

For pen models, a 20 ms, (50 Hz) or 16.7 ms (60 Hz) integration time is automatically selected depending on the power supply frequency.
For dot models, the integration time is 100 ms (50/60 Hz).

TC Burnout:

ON/OFF selectable (per channel).
Burnout upscale/downscale selectable (common for all channels)
Normal: less than 2 kΩ, burnout: more than 10 MΩ.
Measuring current: approx. 100 nA.

Calculation:

Linear scaling:
Ranges: DCV
Scaling limits: -19999 to 20000
Data display & printout range: -19999 to 20000
Decimal points: User-set (specified when entering scale value)
Offset function:
Ranges: DCV, TC, RTD, SCL
Compensation range: within 10% of recording span

Recording and Printing

Recording Method:

Pen model: Disposable felt pens
Dot model: 6 color wire dot.

Effective Recording Width:

100 mm

Chart: Plain-paper Z-fold chart (16 m)

Step Response Time (pen):

approx. 2 sec/acc. to IEC 1143-1 (95% response time)

Recording Period:

Pen model:

Continuous for each channel.

Dot model:

Max. 30 sec/6 channel, AUTO/FIX selectable

AUTO: Analog recording interval is depending on the chart speed

Chart speed	Recording interval
10 mm/h	90 sec
15 mm/h	60 sec
20 mm/h	40 sec
over 25 mm/h	30 sec

T04.EPS

FIX: Analog recording interval is set to shortest period

Chart speed:

User can select the chart speed which is mentioned below by front panel key.

Pen model (21 speeds): (mm/h)

10	15	20	25	30	40	50
60	75	80	90	100	120	150
200	300	600	1200	1500	3000	6000

T05.EPS

Dot model (18 speeds): (mm/h)

10	15	20	25	30	40	50
60	75	80	90	100	120	150
200	300	600	1200			

T06.EPS

Chart Speed Chage:

speed 1, speed 2 change by remote control signals (option).

Chart Speed Accuracy:

within ±0.1% (for recording longer than 1000 mm, related to the grid of the chart paper)

Recording Colors:

Pen model:
pen 1=red, pen2=green, pen3=blue
Dot model:
ch1=purple, ch2=red, ch3=green, ch4=blue, ch5=brown, ch6=black

Display

Display Method:

LED (7 segments, 2+5 characters).

Digital Display:

AUTO Channel No., kind of alarm, measured values, for each channel alternately
MAN Channel No., kind of alarm, measured values, for one specific channel
OFF No display

Other Displays:

RCD: Recording in progress
ALM: Shared alarm (not corresponding to any channel)

Power Supply

Rated Power Voltage:

100 to 240 V AC automatically selected depending on the power supply voltage

Usable power voltage ranges:

90 to 132, 180 to 250 V AC

Rated Power Frequency:

50/60 Hz, automatically selected

Power Consumption:

(approx.)

	100 V AC Power Source	240 V AC Power Source	Maximum
1 pen	14.5 VA*	22.3 VA*	40 VA
2 pen	15.5 VA*	24.0 VA*	40 VA
3 pen	16.5 VA*	25.0 VA*	40 VA
6 dot	13.8 VA*	21.5 VA*	40 VA

*: In Balance

T07.EPS

Alarm**Number of alarm levels:**

Up to two levels can be set for each channel (high, low).

Display: Alarm status (ALM) is displayed.**Hysteresis:** Can be switched between approximately 0.5% (for high or low alarms only) and 0% (common for all channels and alarm levels) of recording span.**Other Specifications****Panel key-lock:**

Can be set for [RCD], [FEED] key

Setting data protection:

Requires a password

Insulation Resistance:

Each terminal to ground terminal: more than 20 MΩ (measured at 500 V DC).

Dielectric strength:

Power supply to ground terminal:
1500 V AC (50/60 Hz), 1 min

Contact output terminal to ground:
1500 V AC (50/60 Hz), 1 min

Measuring input terminal to ground:
1000 V AC (50/60 Hz), 1 min

Between measuring input terminals:
1000 V AC (50/60 Hz), 1 min
(except for RTD, since b-terminal is common).

Between remote control terminal to ground:
500 V DC, 1 min.

Machine noise:

Machine Noise Information Ordinance 3.
GSGV, Jan. 18, 1991:
The maximum sound pressure level is equal or less than 60 dB (A) according to ISO7779.

Safety Standards

Certified by CSA22.2 No. 1010.1
Complies with EN61010-1

EMC Standards

Complies with EN55011 Group 1 Class A
Complies with EN50082-2

IEC1000-4-2: Electrostatic discharge
8 kV (aerial discharge)
4 kV (contact discharge)
Performance criteria B

IEC1000-4-3: 80 to 1000 MHz, 10 V/m
Performance criteria A
(±50% of range)

IEC1000-4-4: Fast transient burst
AC powerline: 2 kV
Others: 1 kV
Performance criteria B

IEC1000-4-6: 0.15 to 80 MHz, 10 V/m
Performance criteria A
(±50% of range)

Normal Operating Conditions**Power voltage:**

90 to 132, 180 to 250 V AC

Power frequency:

50 Hz±2%, 60 Hz±2%

Ambient temperature:

0 to 50°C

Ambient humidity:

20 to 80% RH (at 5 to 40°C)

Vibration: 10 to 60 Hz, less than 0.2 m/s²**Shock:** not permissible**Magnetic field:**

less than 400 AT/m (DC and 50, 60 Hz)

Noise: Normal Mode (50/60 Hz)

DCV Peak value including signal must be less than 1.2 times the measuring range.

TC Peak value including signal must be less than 1.2 times the measuring thermal electromotive force.

RTD less than 50 mV.

Common Mode (50/60 Hz)

less than 250 V AC rms. for the whole range

Maximum Differential Noise between

Channels (50/60 Hz)

Less than 250 V AC rms

Operating Position:

Can be tilted backward up to 30° from vertical. Must not be tilted to the left or right.

Warm-up Time:

Min 30 minutes after power has been turned ON.

Standard Performance

Measuring and Recording Accuracy:

(following specifications apply to operation of the recorder under standard operation conditions: temperature 23±2°C, humidity 55±10% RH, power supply voltage 90 to 132 V, 180 to 250 V AC, power supply frequency 50/60 Hz ±1%, warm-up time at least 30 minutes, other ambient conditions like vibration should not adversely affect the recording operation).

Input	Range	Measuring (digital display)		Recording (analog)	
		Measurement Accuracy	Max. Resolution	Recording Accuracy	Resolution
DC V	20 mV	±(0.2% of rdg+3 digits)	10 µV	Measurement accuracy ±(0.3% of recording span)	Pen model dead band: 0.2% of recording span Dot model resolution: 0.1 mm
	60 mV	±(0.2% of rdg+3 digits)	10 µV		
	200 mV	±(0.2% of rdg+3 digits)	100 µV		
	2 V	±(0.2% of rdg+3 digits)	1 mV		
	6 V	±(0.3% of rdg+4 digits)	1 mV		
	20 V	±(0.3% of rdg+3 digits)	10 mV		
TC Does not include reference junction compensation accuracy	R S B	±(0.2% of rdg+1.7°C) but R, S: 0 to 100°C, ±4.0°C 100 to 300°C, ±2.2°C B: 400 to 600°C, ±3.7°C accuracy less than 400°C is not specified	0.1°C	Measurement accuracy ±(0.3% of recording span)	Pen model dead band: 0.2% of recording span Dot model resolution: 0.1 mm
	K	±(0.2% of rdg+0.7°C) but -200 to -100°C ±(0.2% of rdg+1.6°C)	0.1°C		
	E	±(0.2% of rdg+0.5°C) but: -200 to -100°C	0.1°C		
	J	±(0.2% of rdg+1.3°C) -100 to 0°C			
	L	±(0.2% of rdg+0.6°C)	0.1°C		
	N	±(0.15% of rdg+0.7°C)			
	W	±(0.15% of rdg+1°C)	0.1°C		
	T U	±(0.2% of rdg+0.5°C) but: -200 to -100°C ±(0.2% of rdg+1.6°C) -100 to 0°C ±(0.2% of rdg+0.8°C)	0.1°C		
RTD	Pt100 JPt100	±(0.2% of rdg+0.5°C)	0.1°C	Measurement accuracy ±(0.3% of recording span)	Pen model dead band: 0.2% of recording span Dot model resolution: 0.1 mm

NOTE: Recording span is 100 mm.

T08.EPS

Accuracy in case of scaling:
accuracy during scaling (digits)=
measuring accuracy (digits)x multiplier+2
digits (rounded up)
Where the multiplier=
scaling span digits/recording span digits

Example:
DCV 6 V range
recording span: 1.000 to 5.000 V
scaling span: 0.000 to 2.000
measuring accuracy=±(0.3% x 5 V+2 digits)
±(0.015 V (15 digits)+2)
±(17 digits)
multiplier= 2000 digits (0.000 to 2.000)/4000
digits (1.000 to 5.000 V)=0.5
Accuracy during scaling=
17 digits x 0.5+2=11 digits (rounded up)

Maximum Allowable Input Voltage:

Less than 2 V DC ranges and TC ranges:
 ± 10 V DC (cont.)
 6 V to 20 V DC: ± 30 V DC (cont.)

Reference Junction Compensation:

internal

Reference Junction Compensation Accuracy (above 0°C)

Type R, S, B, W: $\pm 1^\circ\text{C}$
 Type K, J, E, T, N, L, U: $\pm 0.7^\circ\text{C}$
 but 0.0 to -50.0°C : $\pm 0.8^\circ\text{C}$
 -50.0 to -100.0°C : $\pm 0.9^\circ\text{C}$
 -100.0 to -150.0°C : $\pm 1.3^\circ\text{C}$
 -150.0 to -200.0°C : $\pm 1.7^\circ\text{C}$

Input Resistance:

More than 10 M Ω (TC, 20 mV, 60 mV, 200 mV, 2 V range)
 Approx. 1M Ω (6, 20 V range).

Input Source Resistance:

DCV, TC input: less than 2 k Ω
 RTD input: less than 10 Ω /wire (Resistance is well-balanced between 3 wires)

Input Bias Current:

less than 10 nA (however, when burnout is specified for TC: 100 nA).

Maximum Common Mode Voltage:

250 V AC rms (50/60 Hz)

Maximum Differential Noise between Channels:

250 V AC rms (50/60 Hz)

Interference between Channels:

120 dB (500 Ω , the deviation in the case that 30 V is applied to another channel)

Common Mode Rejection Ratio:

120 dB (50/60 Hz $\pm 0.1\%$, 500 Ω imbalance between \ominus terminal and ground)

Normal Mode Rejection Ratio:

40 dB (50/60 Hz $\pm 0.1\%$)

Effect of Operating Conditions**Effect of Ambient Temperature:**

Effect of ambient temperature variation of 10°C .
 Digital display: within $\pm(0.1\%$ of rdg+1 digit)
 Recording: within Digital display $\pm 0.2\%$ of recording span (excluding RJC error)

Effect of Power Supply:

Effect of variation within 90 to 132 V or 180 to 250 V AC in rated power supply voltage: (50 or 60 Hz is reference)
 Digital display: within ± 1 digit
 Recording: within $\pm 0.1\%$ of recording span
 Effect of rated power frequency variation of ± 2 Hz (100 V AC is reference):
 Digital display: within $\pm(0.1\%$ of rdg+1 digit)
 Recording: same as digital display

Effect of Magnetic Field

Effect of AC (50/60 Hz) or DC 400 AT/m field:
 Digital display: within $\pm(0.1\%$ of rdg+10 digits)
 Recording: less than $\pm 0.5\%$ of recording span

Effect of Input Source Resistance:

Effect of Input Source Resistance variation of +1 k Ω :
 DCV range:
 Ranges less than 2 V: within ± 10 μV

Ranges more than 6 V: within -0.1% of rdg

TC range:

within ± 10 μV (However ± 100 μV when TC burnout protection is set)

RTD range:

i) Effects of changes of 10 Ω per wire (when resistance of all three wires are equal):

Digital display: within $\pm(0.1\%$ of rdg+1 digit)

Recording: within (display change [above] $\pm 0.1\%$ of recording span)

ii) Effect of differences in the resistances of the three wires:

Digital display: approx. 0.1°C per 40 m Ω (maximum difference between the three wires)

Effect of Operating Position:

Digital display: within $\pm(0.1\%$ of rdg+1 digit) (within 30° backwards)

Recording: within Digital display $\pm 0.1\%$ of recording span (within 30° backwards)

Vibration: Effect when sine-wave motion of frequency

10 to 60 Hz and acceleration of 0.2 m/s² is applied to the instrument in the direction of three axes for two hours:

Digital display: within $\pm(0.1\%$ of rdg+1 digit)

Recording: within Digital display $\pm 0.1\%$ of recording span

Transport and Storage Conditions

No malfunction will occur under these conditions, however when returning to normal operating conditions, calibration might be necessary.

Temperature:

-25°C to 60°C

Humidity: 5 to 95% RH (no condensation)**Vibration:** 10 to 60 Hz 4.9 m/s²**Shock:** less than 392 m/s² (inside packing)**SPECIFICATIONS OF OPTIONAL FUNCTIONS****/A1: Alarm Output Relay (2 contacts)****/A2: Alarm Output Relay (4 contacts)**

When an alarm occurs, the output relay on the rear terminal will be activated.

- OR output
- Energize/de-energize can be selected (common for all relays)
- Relay contact rating: 250 V DC at 0.1 A
250 V AC at 3 A
- Type of relay output: SPDT

/D2: Temperature Unit Change

To use $^\circ\text{F}$ as temperature unit

/R1: Remote Control

Can perform two commands from any of the following:

	Number of settings	Signal level
• Recording start/stop	1	level
• Chart speed changes	1	level

MODEL AND SUFFIX CODES

Model	Suffix Code	Description
SR11	-E	SR10 1-pen recorder
SR12	-E	SR10 2-pen recorder
SR13	-E	SR10 3-pen recorder
SR16	-E	SR10 6 dot recorder
Input Types	-1	DC voltage (DCV), thermocouple (TC)
	-2	Resistance temperature detector (RTD)
Optional Functions	/ <input type="checkbox"/>	Refer to the option codes

“-E” must be specified.

“-2” can be selected for Dot model only.

T09.EPS

STANDARD ACCESSORIES

Name	1-pen	2-pen	3-pen	6-wire
Z-fold chart	1	1	1	1
6 color ribbon cassette	-	-	-	1
Disposable felt-pen cartridge	Red	1	1	-
	Green	-	1	-
	Blue	-	-	1
Mounting brackets	2	2	2	2
Instruction Manual	1	1	1	1

T10.EPS

SPARES

Name	Parts No.	Order Q'ty (units)	Description
Z-fold chart	B9565AW	10	1 chart/unit
6 color ribbon cassette	B9963AW	1	1 piece/unit
Disposable felt-pen cartridge	Red	B9902AM	1
	Green	B9902AN	1
	Blue	B9902AP	1
Mounting brackets	B9962CG	2	1 piece/unit

T11.EPS

OPTION CODES

Option Code	Description
/A1*1	Alarm relay output contact (2 contacts)
/A2*1	Alarm relay output contact (4 contacts)
/D2	Fahrenheit temperature units (°F)
/R1	Remote control

Note 1: only one of /A1, /A2 can be selected.

T12.EPS

OPTIONAL ACCESSORIES

Name	Model Code	Specification
Shunt resistor	4159 20	250 Ω ±0.1%
	4159 21	100 Ω ±0.1%
	4159 22	10 Ω ±0.1%

T13.EPS

VIEW OF REAR TERMINAL BLOCKS

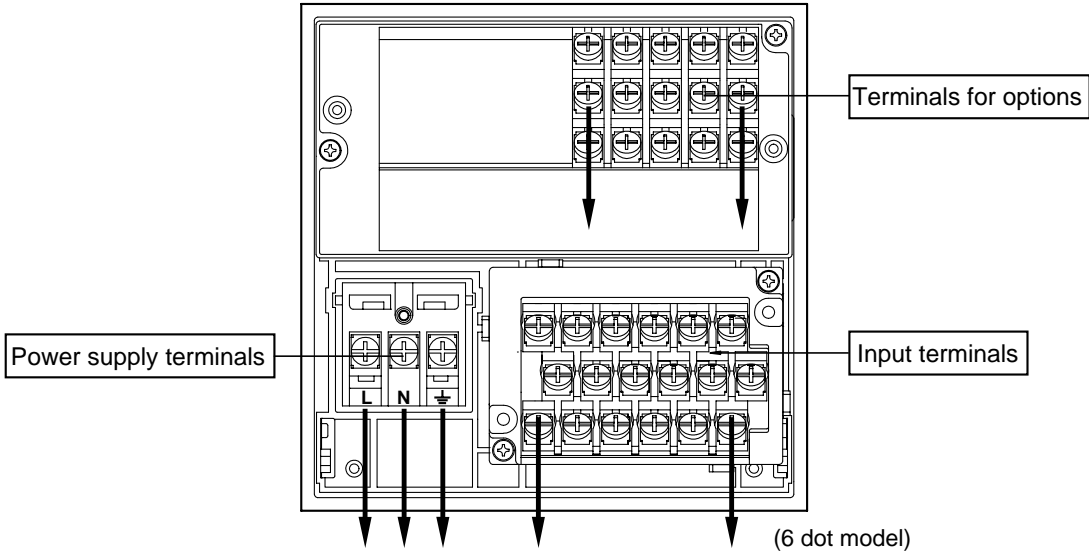

Note: The arrows indicate the direction in which the wires connected to the terminals should run for external connection.

Input Terminals

Screw Terminals on 3-pen Model

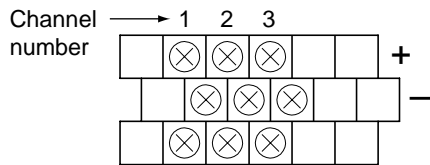

Screw Terminals on 6 Dot Model

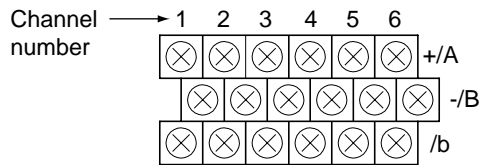

Terminals for Options

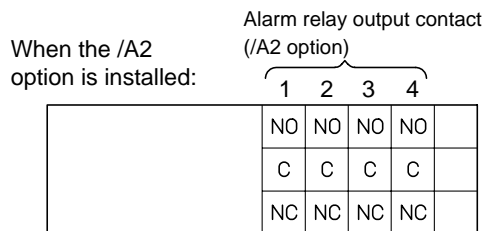
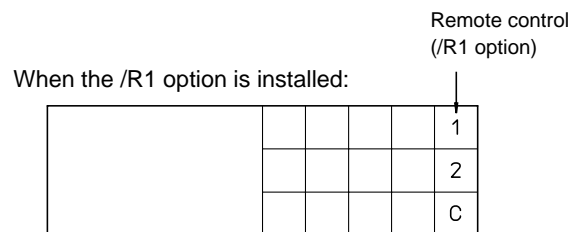
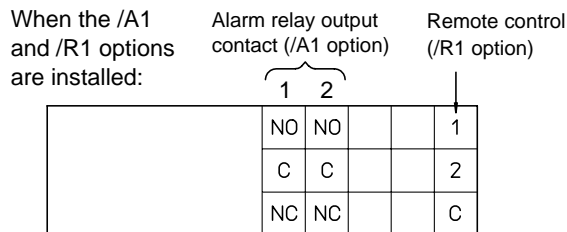
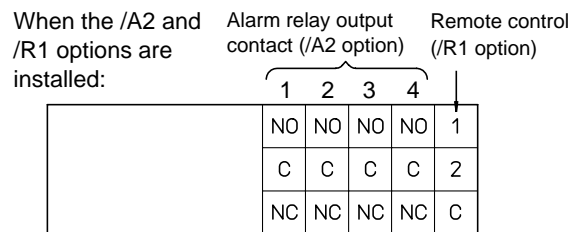
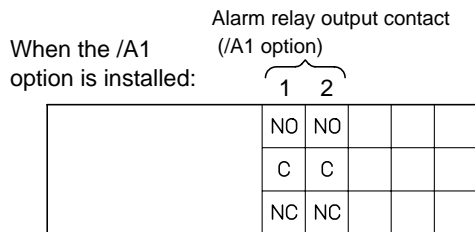

DIMENSIONS

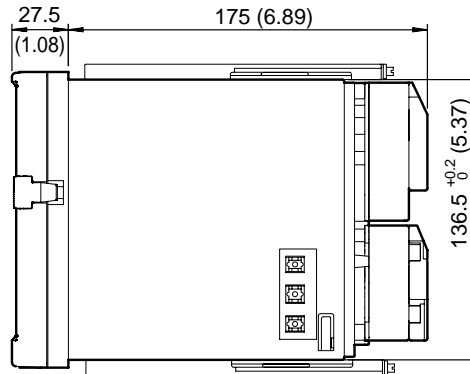
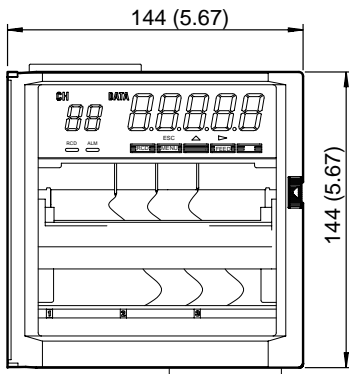
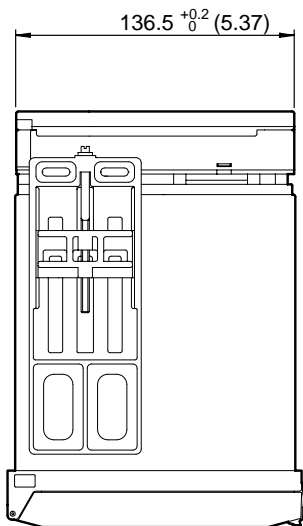
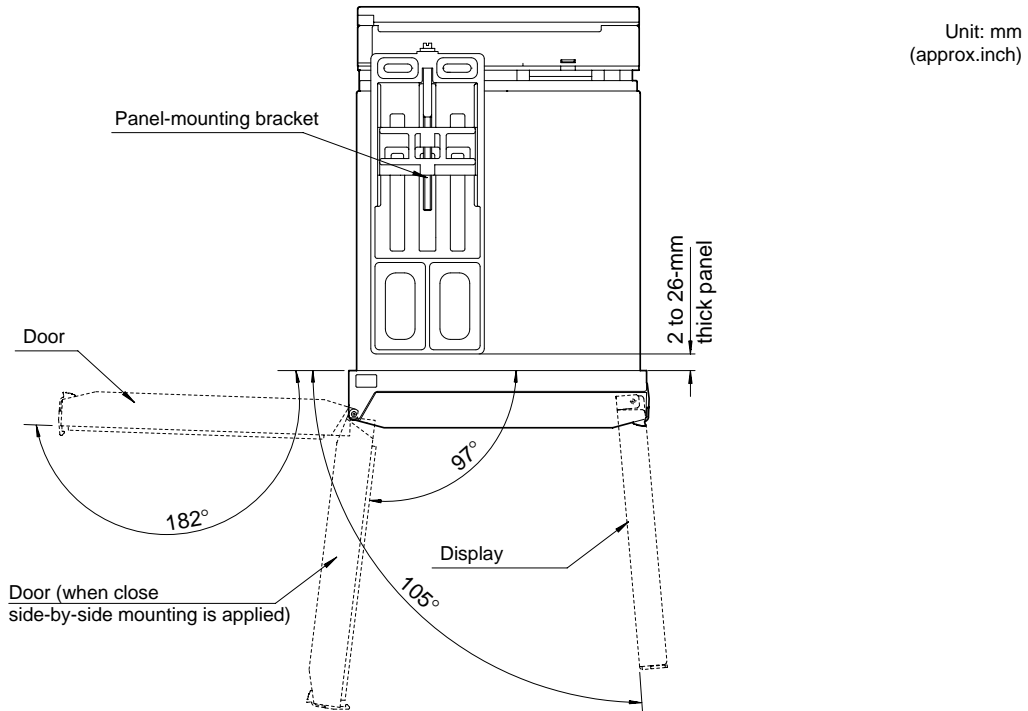

Unless otherwise specified, the dimensional tolerance is $\pm 3\%$ (or ± 0.3 mm for dimensions smaller than 10 mm).

F02.EPS

■ PANEL CUTOUT & SPACING

Unit: mm
(approx. inch)

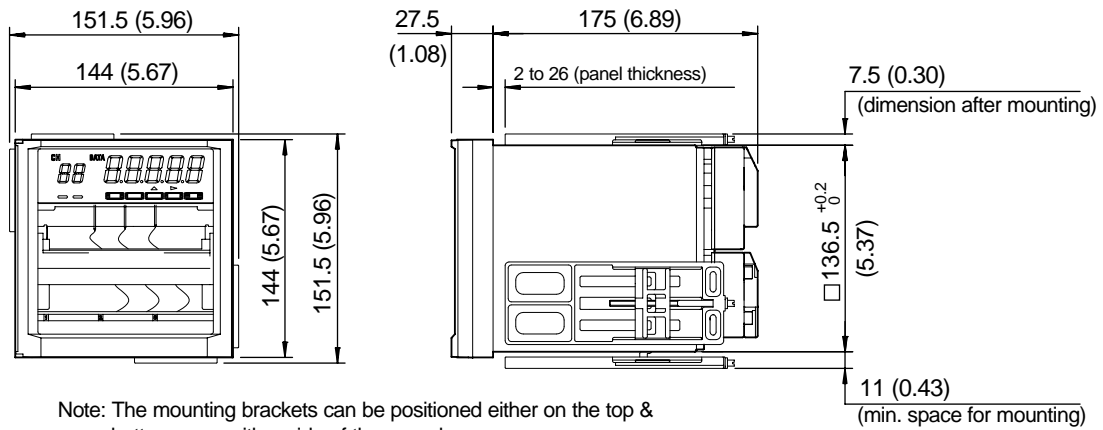

Note: The mounting brackets can be positioned either on the top & bottom or on either side of the recorder.

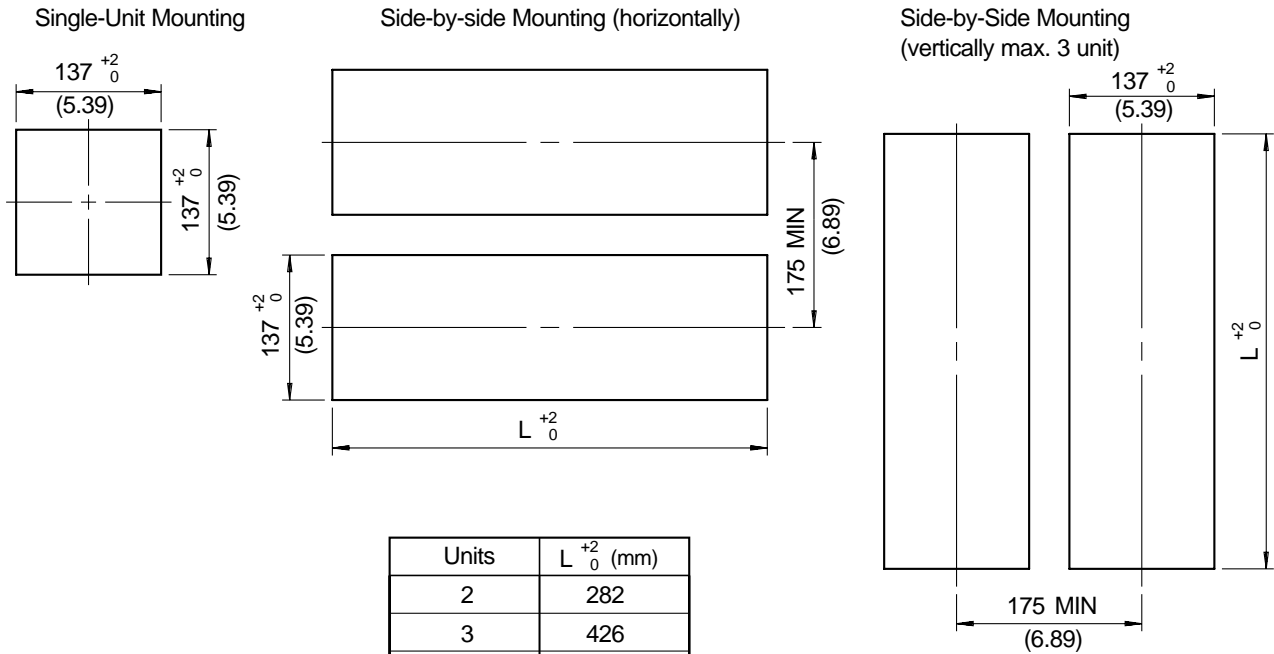

Units	L ⁺² ₀ (mm)
2	282
3	426
4	570
5	714
6	858
7	1002
8	1146
9	1290
10	1434
n	(144 x n)-6

Note: Unless otherwise specified, the tolerance is ±3%. However, in cases of less than 10 mm, the tolerance is ±0.3 mm.

F03.EPS

Relationship between Bezel Height of Peripheral Equipment and Space between Measurement Instruments

(In case mounted at the left side of SR10)

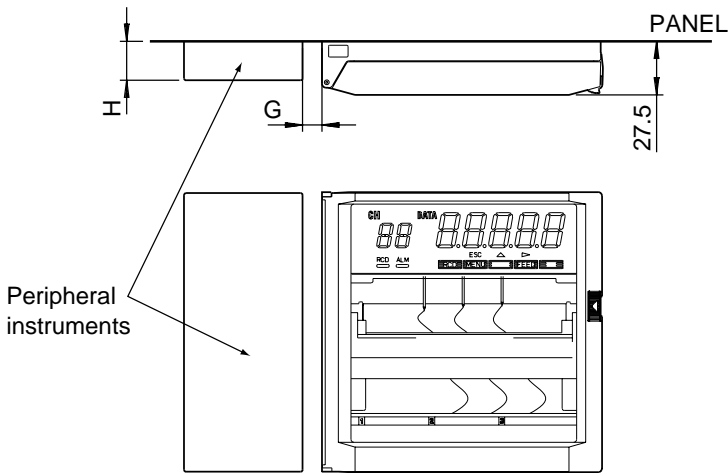

Height of Bezel from Panel Less than H (mm)	Space More than G (mm)
20	0
24	1
28	2
32	3
More than 36 unlimited	4

Note: For instruments which do not have taper and angle R

(In case mounted at the right side of SR10)

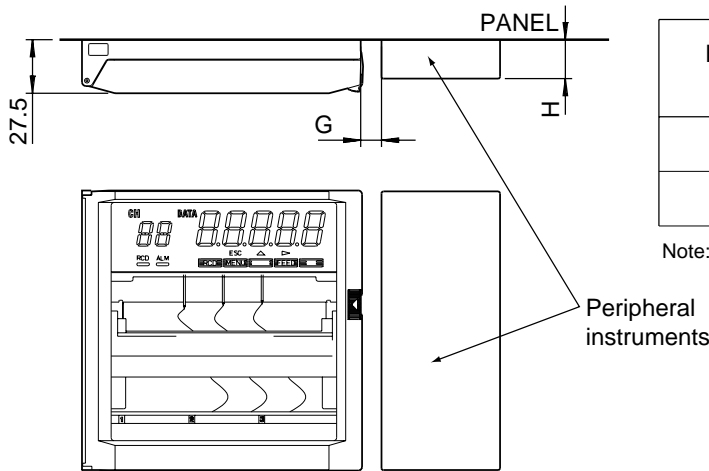

Height of Bezel from Panel ; H (mm)	Space ; G (mm)
less than 23.5	0
more than 23.5	3

Note: For instruments which do not have taper and angle R

F04.EPS